

Scheda dati | Codice articolo: 221-509

Supporto di montaggio con piastra antistrappo; connettori per 10 cavi; Serie 221 - 4 mm²; per montaggio a vite; bianco

<https://www.wago.com/221-509>

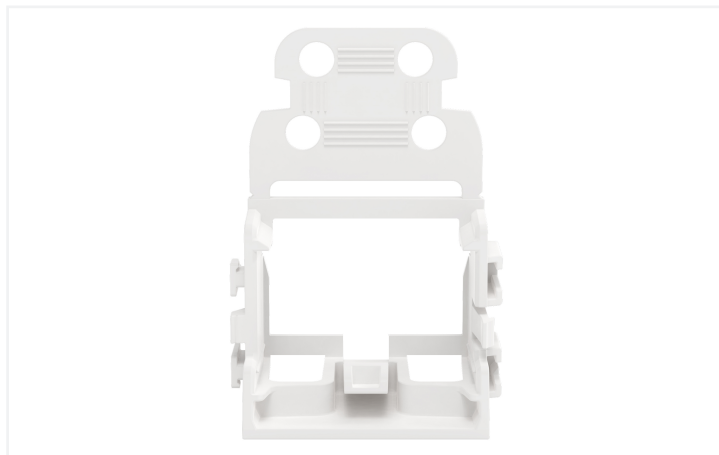

Colore: ■ bianco

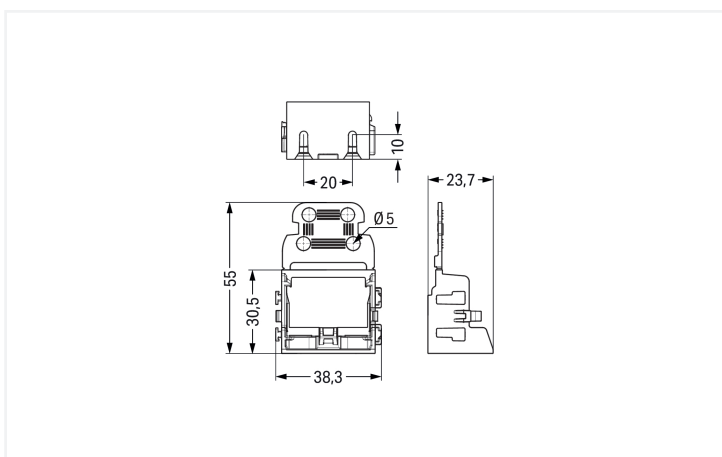

Dati geometrici

Larghezza	38,3 mm / 1.508 pollici
Altezza	55 mm / 2.165 pollici
Profondità	23,7 mm / 0.993 pollici

Dati meccanici

Tipo montaggio	Fissaggio a vite
Adatto	for 10-wire connectors (4 mm ²)

Dati dei materiali

Nota sui dati dei materiali	Information on material specifications can be found here
Colore	bianco
Gruppo materiale	I
Materiale isolante	Poliammide (PA66)
Classe di infiammabilità secondo UL 94	V0
Carico d'incendio	0.158 MJ
Peso	5,9 g

Dati commerciali

PU (SPU)	10 pz.
Tipo imballaggio	Box
Paese d'origine	CN
GTIN	4066966602975
Numero tariffa doganale	39269097900

Product Classification

ETIM 9.0	EC002848
ETIM 10.0	EC002848
ECCN	NO US CLASSIFICATION

Environmental Product Compliance

RoHS Compliance Status	Compliant, No Exemption
------------------------	-------------------------

Download

Environmental Product Compliance

Compliance Search

Environmental Product
Compliance 221-509



CAD/CAE-Data

CAD data

2D/3D Models 221-509



1 Prodotti compatibili

1.1 Accessori opzionali

1.1.1 Marcatura

1.1.1.1 Striscia di marcatura



N. art.: 210-833

Strisce di marcatura; 25 m su bobina;
larghezza 6 mm; vuoto; Autoadesivo; bianco